

ZW series

HITACHI

ZW  
140



## WHEEL LOADER

- **Model Code:** ZW140
- **Operating Weight:** 10 240 - 10 540 kg
- **Bucket Capacity:** ISO Heaped: 1.5 - 2.3 m<sup>3</sup>
- **Max. Engine Output:** 96 kW (129 HP)

# Introducing the New-Generation Wheel Loaders:

# ZW Series

## Light, Agile Footwork Plus Increased Productivity

The ZW140 is packed with numerous innovative technologies and mechanisms. The electronic control HST system makes possible light, agile footwork. Four work modes can be selected according to job needs, with best matching of traction force and breakout force. What's more, the ZW140 offers more impressive features: operating ease, enhanced safety, increased durability, and simplified maintenance.

### Productivity

Four work modes selectable to suit job needs  
2-Motor HST system for powerful acceleration and higher travel speed (Maximum 39 km/h)  
Throttle limit for higher fuel efficiency  
Improved fundamental performance  
Smooth speed shift by electronic control  
High-torque engine  
Torque proportional differential (Standard)  
Limited slip differential (Optional)  
Advanced speed selector for four maximum speeds  
The first speed selector for efficient loading and operations in confined space  
Inching pedal for easy positioning in confined space  
Ride control system (Optional)  
**Pages 4-7**

### Panoramic comfortable cab

Bi-level auto air conditioner and pressurized cab  
Front & rear defrosters  
Low noise design  
Panoramic cab  
Enhanced upward visibility  
Good rear visibility  
Ergonomically positioned switches and controls  
Air suspension seat  
**Pages 8-9**

### Enhanced Durability

Robust differential gears  
Durable axles  
Robust frame  
Hydraulically operated cooling fan with heat-sensing system  
Capacious hydraulic oil cooler  
Protected fuel tank  
Aluminum radiator and oil cooler  
LED indicators and instruments  
O-Ring Seal (ORS) joints and water-resistant electric connectors  
**Pages 10-11**

### Easy Maintenance

Conveniently located filters  
Easy-to-replace air conditioning filters  
HN bushings  
Strategically located Fuel supply port  
Easy-to-read monitor  
Flat cab floor  
Dirt-Less (DL) front frame  
**Pages 12-13**

### Safety

Full fan guard  
Emergency steering system (Optional)  
Mis-operation protection  
ROPS / FOPS cab  
Highly reliable dual-line brake system  
Other safety features  
**Page 14**

### Environment

Common rail fuel injection system  
Hitachi Silent (HS) fan  
Low noise engine  
A recyclable machine  
**Page 15**

### Specifications

**Pages 16-19**



- The new engine complies with the Emission Regulations U.S EPA Tier3, and EU Stage III A
- The advanced low noise design complies with the coming EU noise regulation 2000 / 14 / EC, STAGE II

*Note: Pictures may or may not include standard and optional equipment that are specified individually by countries.*

# Increased Productivity with Advanced HST System, an Hitachi Original Technology

Optimum traction force can be selected to suit job needs by electronic matching control. The HST system is further improved for increased job efficiency.

## Four work modes selectable to suit job needs



Work mode select switch

On the ZW140, four work modes are selectable according to job requirements and operator's preference. In each work mode, electronic matching control, originally developed by Hitachi, detects the pressure of the implement, and controls the torque of travel motor to best match traction force and breakout force. This increases production per unit of fuel.

**Normal Operation (Work P, N and L Modes)**

Efficient loading with optimum traction force to suit job needs

**Snow Plowing (Work S Mode)**

Efficient snow plowing with optimum traction force, reducing slippage on snow

## Four Work Modes

Work Modes	Materials to Be Handled
<b>P mode</b> (Scooping up and crowding)	<ul style="list-style-type: none"> <li>Relatively large crushed stones</li> <li>Concrete slag</li> <li>Stone with large specific gravity, clayey soil</li> </ul>
<b>N mode</b> (Normal operation)	<ul style="list-style-type: none"> <li>Small crushed stones</li> <li>Gravel</li> <li>Cobble</li> </ul>
<b>L mode</b> (Loading and light excavation)	<ul style="list-style-type: none"> <li>Sand</li> <li>Plastics, industrial wastes, chips</li> </ul>
<b>S mode</b> (Snow plowing and swamp operation)	<ul style="list-style-type: none"> <li>Snow</li> </ul>

## Matching Control

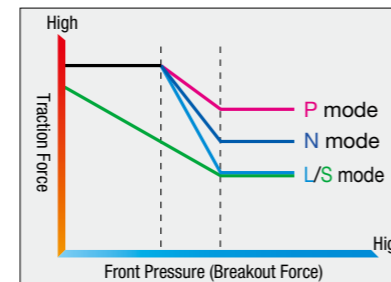

Traction force and front pressure are well balanced by work mode. If you need big traction force, select the P mode.

## 2-Motor HST System for Powerful Acceleration and Higher Travel Speed (Maximum 39 km/h)

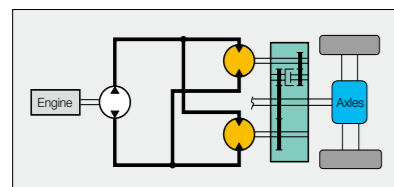

The two-motor HST system is newly developed to achieve high-efficient operation in a wide speed range. For instance, at a low speed, two motors yield high traction torque, while at a high speed, a single motor allows for high travel speed of 39 km/h. Moreover, this system makes possible easy slope climbing and smooth acceleration/deceleration with the accelerator pedal only.

## Throttle Limit for Higher Fuel Efficiency



Throttle limit switch

The throttle limit cuts maximum engine speed by 10% for higher fuel efficiency. For the HST system, maximum traction force is not reduced with the reduction in engine speed.

Throttle limit switch	*ON
Fuel consumption (L/h)	88 %
Production (m <sup>3</sup> /h)	93 %
Fuel efficiency (m <sup>3</sup> /L)	106 %

\*Index: 100 = Throttle limit switch OFF  
Note: Data shown is Hitachi test data, and may vary depending on job conditions.



## Improved Fundamental Performance

**Big Traction Force**

Traction force	kN	87
Bucket breakout force	kN	92

**Big Dumping Clearance and Reach (when 2.0 m<sup>3</sup> bucket with BOC is fitted)**

Dumping clearance	2 840 mm
Dumping reach	900 mm

## Smooth Speed Shift by Electronic Control

Speed shift can be continuously made by electronic control through the 2-motor HST system comprising helical gears. This allows for speedy job-to-job travel with less soil spills in load-and-carry operation.

## High-Torque Engine

Max. output : **96 kW (129 HP)**  
Max. torque : **540 N·m (55 kgf·m)**

The new engine is ruggedly designed to yield big torque with less vibration for increased durability. This facilitates climbing steep slopes and long uphill with limited speed drop. This engine is a clean engine that complies with the latest global emission regulations.

## Torque Proportional Differential (Standard)

The torque proportional differential adjusts driving forces to both wheels. When road resistances under both wheels are different, this feature minimizes slippage of a wheel on softer ground, unlike conventional differentials. This feature enables the ZW series to get out of swamps or rough terrain easily.

## Limited Slip Differential (Optional)

On snowy roads and rough terrain, the limited slip differential can work instead of the torque proportional differential. This delivers effective driving force to both wheels for enhanced grip and less slippage during travel.

# Agile Footwork for Increased Productivity

Fast, light footwork. Speed selection to suit job needs. Improved controllability and combined operations. Those bring about high productivity.

## Advanced Speed Selector for Four Maximum Speeds



The fully automatic HST system is utilized for the selection of four maximum speeds according to job needs. Optimum speed can be selected with less shocks for smooth travel.

## The First Speed Selector for Efficient Loading and Operations in Confined Space



When the first speed range is selected, four travel speeds can be further selected to suit job needs and jobsite conditions. No need for skilful control of the accelerator and brake.

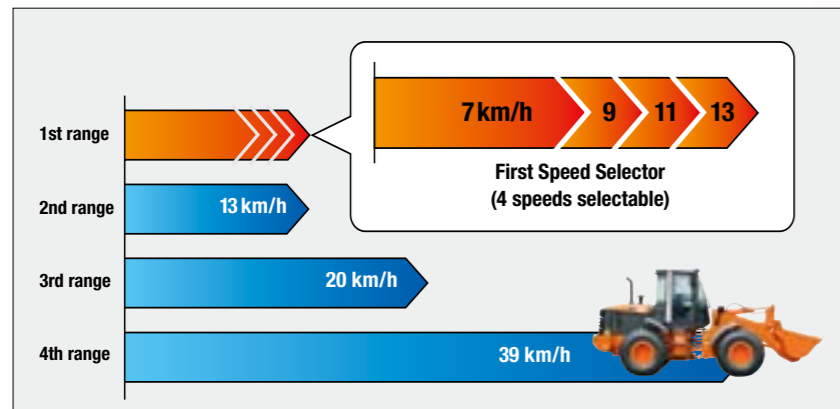

## Inching Pedal for Easy Positioning in Confined Space



The operator can easily control travel speed with the inching pedal, regardless of the accelerator pedal, by adjusting the delivery flow from the hydraulic pump. This eases positioning in loading operation.

## New Hydraulic Circuit for Smoothly Combined Operation



With the new parallel/tandem hydraulic circuit, the lift arm and bucket can be operated simultaneously. This is a new function to increase loading and excavating efficiency.

## Sophisticated Mechanisms for Higher Job Efficiency

### Float System

The float system lets the lift arm follow up road irregularities by using its self-weight only, without using its hydraulic circuit. This system is useful in soil-spill collecting during loading, and snow removing.

### Lift Arm Kick-Out System (Optional)

The lift arm can automatically be raised up to the preset level. This function is convenient when loading onto a dump truck, and when operating at confined job sites with restricted working height.

### Bucket Auto Leveler

The bucket can automatically be leveled parallel to the ground after dumping the bucket. This can eliminate cumbersome bucket repositioning for efficient loading.

## Operator-Friendly Designs for Higher Job Efficiency

### Restriction Valve

The restriction valve can effectively reduce shocks when stopping the lift arm. The bucket does not have a shockless circuit to allow efficient mud removal.

### Ride Control System (Optional)

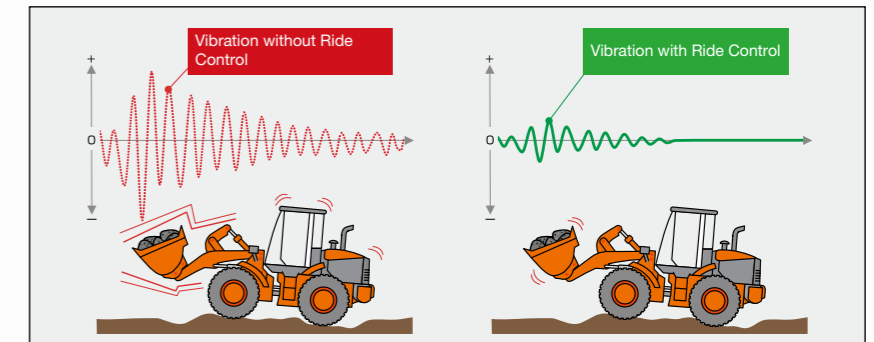

The ride control reduces pitching and bouncing during traveling on rough terrain and snow road by automatic control of the implement. Shocks and vibration can be well suppressed for riding comfort.





## Operator-First Designs: Easy-to-Handle Controls for Operator Comfort

### Panoramic Cab



The panoramic cab gives almost all-round visibility with the widened front glass window and pillar less cab rear corners. Front wheels are always in the operator's vision, enhancing safety and increasing loading efficiency.

### Enhanced Upward Visibility

The front curved glass window gives good upward visibility, so the operator can directly see the movement of the bucket for safer loading.

### Good Rear Visibility

The engine cover is low profile, and rounded for better rear visibility, so the operator can directly see the rear wheels and counterweight.

### Multi-Functional Joystick Lever (Optional)



The multi-functional joystick lever is provided atop of the control lever for operating ease.

### Comfort-Designed Suspension Seat



The mechanical suspension seat well absorbs shocks and vibrations from the machine's body to reduce operator's physical stresses for enhanced comfort.

The air suspension seat is an option.

### Bi-Level Auto Air Conditioner and Pressurized Cab



The bi-level air conditioner allows air conditioning at foot space and overhead simultaneously. Airflow volume and direction can automatically be adjusted according to the temperature setting. The pressurized cab shuts out dust and debris even in dusty environment.

### Front / Rear Defrosters



With the front and rear defrosters, airflow comes out from three front air outlets and two rear outlets to protect respective windows from fogging, keeping clear vision even in rain and cold weather.

### Shock-Dampened Cab



The cab rests on fluid-filled elastic mounts to absorb shocks and vibration, and reduce resonance.

### Low Noise Design

The cab is well sealed, and the new low-noise engine is utilized to reduce sound, along with the following measures:

- Hydraulically operated cooling fan with heat-sensing system
- Hitachi Silent (HS) fan
- Sound-absorbing materials inside engine cover and cab

### Ergonomically Positioned Switches and Controls



The switches for pre-operation setting are on the right console, and the switches for operation and travel on the front console. They are functionally laid out for ease of operation.

### Hat (Resin Cab Roof)



The hollow hat is provided atop the cab to form an air space. This greatly helps reduce the temperature rise in the cab, and increases the cooling efficiency of the air conditioner.

### An Array of Standard Accessories



Hot and cool box

Large tray and drink holder

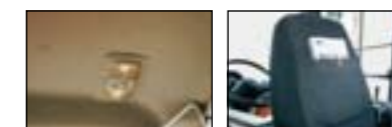

Interior light interacting with cab door

Seatback pocket holder



AM / FM stereo radio

Sun visor

# Enhanced Durability

Durability is enhanced with a number of advanced mechanisms for long, continuous operation.

## Dependable Drive System



**Durable Axles**  
Front and rear axles are improved for durability. The axle housing is thickened for tough operation at quarries.

**Robust Differential Gears**  
Differential gears are thickened to increase rigidity.

**Improved Braking Ability**  
The brake is a wet-type multi-plate brake, and housed in the axle.

## Robust Frame



The box-section frame is thickened and strengthened to resist torsion and increase durability. Center pins are widely spaced for higher resistance to torsion.

## Hydraulically Operated Cooling Fan with Heat-Sensing System



Fan speed can be adjusted depending on fluid temperature to effectively cool down coolant and hydraulic oil. The result is extended component service life and reduction in fuel consumption. The fan is also separate from the engine for easy servicing.

**Capacious Hydraulic Oil Cooler**  
The ample cooling capacity of the hydraulic oil cooler helps reduce oil temperature fluctuation, and extend service life of components.

## Protected Fuel Tank



The large counterweight is arranged to protect the fuel tank from collisions with obstacles during operation.

## Aluminum Radiator and Oil Cooler



The radiator and oil cooler are made of aluminum instead of conventional steel or copper for corrosion prevention.

## LED Indicators and Instruments



On the indicators, monitors and alarms, many LEDs are utilized for longer service life resulting in less failure, enhancing the reliability.

## O-Ring Seal (ORS) Joints and Water-Resistant Electric Connectors



Numerous elaborate components are utilized for higher durability and reliability. The proven ORS joints and high-pressure hydraulic lines are utilized in the hydraulic system, and water-resistant wiring connectors in the electrical system.



# Reduced Running Costs

Running and maintenance costs are reduced greatly with concentrated inspecting points and durable components.



## Easy-to-Replace Air Conditioning Filters



The fresh air filter can easily be replaced from the cab, and circulation air filter also replaced by detaching the drink holder.

## Conveniently Located Filters

Fuel filter, fuel pre-filter with sedimentary function and engine oil filter are strategically located for the convenient daily inspection and servicing.

## Extended Engine Oil Replacement Intervals (Up from 250 to 500 Hours)

Engine oil capacity and filter capacity are increased for longer filter replacement intervals, reducing maintenance time and downtime.

## Easy Draining

The engine oil drain port is located for the convenience of maintenance. No need for reaching under the machine.



## HN Bushings



The HN bushing containing high-viscosity oil is provided at each joint to reduce grease consumption, extend lubrication intervals (100 to 500 hours), and increase durability.

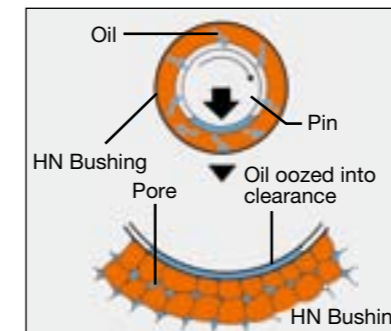

The HN bushing, another example of innovative technology developed by Hitachi, features long life and high durability. High-viscosity oil is vacuum impregnated in sintered high-hardness metal. During operation oil oozes from the pores of the bushing into the clearance between pins and bushing providing lubrication.

## Easy-to-Read Monitor



With the easy-to-read monitor, the operator can see instructions for scheduled servicing and maintenance.

### Monitor Indication Items:

Clock, service intervals, travel speed, mileage, hour meter

### Replacement Alerting:

Engine oil / filter, fuel filter, hydraulic oil / filter, transmission oil / filter, Axle oil.

## Hydraulically Operated Cooling Fan



The rotation of the hydraulically operated cooling fan with heat-sensing system is equipped as standard. The fan itself can swing open for easy cleaning.

## Flat Cab Floor



The cab floor is stepless (flat) for ease of cleaning.

## Strategically Located Fuel Supply Port



The fuel supply port is located for convenient fuel supply from the ground.

## Dirt-Less (DL) Front Frame



The DL front frame is shaped for easy removal of dirt, stones and snow.

# Safety-First Design

Achieving a High-Level of Safety in the Working Environment with an Array of Advanced Mechanisms.



### ROPS / FOPS Cab

The ROPS / FOPS cab is provided to protect the operator from injury in an accident.

*ROPS: Roll-Over Protective Structure:*

*ISO3471*

*FOPS: Falling Object Protective Structure:*

*ISO3449*

### Highly Reliable Dual-Line Brake System

The dual-line hydraulic brake system is utilized: even if one line fails, the other can work for braking. The brake is an enclosed wet single-plate type for reliable braking.

### Full Fan Guard



The cooling fan is enclosed by a full guard (metal net) to protect service technicians from injury during servicing and maintenance.

### Emergency Steering System

The emergency electric pump delivers the necessary oil pressure for power steering even in the case of an emergency. This allows normal steering at all times even if the engine fails.

### Mis-Operation Protection:

**Starting Engine:** The engine will start only when the Forward / Reverse lever is in neutral.

**Starting:** The transmission is disabled when the parking switch is in the ON position, even if selecting Forward or Reverse.

**Leaving from Operator Seat:** Control levers and Forward / Reverse lever are locked to prevent accidental operation.

**Stopping Engine:** The spring-set/hydraulic-released parking brake is automatically applied even if failing to apply it.

### Other Safety Features



Retractable Seat Belt



Inclined Ladder

# Environmentally Friendly Design

## A Cleaner Machine

The ZW Series is equipped with a clean but powerful engine to comply with Tier 3 and Stage III A. An engine emission regulations effective in the U.S. EPA and European Union from 2006. Exhaust gas is partly re-combusted to reduce particulate matter (PM) output and lower nitrogen oxide (NOx) levels.

### Common Rail Type Fuel Injection System

In this fuel injection system complying with the Emission Regulations, one fuel pump runs to generate high pressure for distributing fuel to each injector per cylinder through a common rail. By electronic control, fuel injection volume and timing can be precisely regulated for efficient combustion and higher horsepower. This also reduces PM\* (diesel plume), fuel consumption and vibration.

*\*Particulate matter*

*Important: The use of fuels other than diesel fuel (EN590) is prohibited. Otherwise, the engine may be damaged.*

## A Recyclable Machine



Approximately 95% of the ZW Series can be recycled. The resin parts are marked to facilitate recycling. The machine is completely lead-free. The radiator and oil cooler are made from aluminum and all wires are lead-less. In addition, bio-degradable hydraulic oil is available for jobsites where special environmental care is required.

## A Quieter Machine

A number of features make this machine quieter. First, isochronous control of the engine speed means a restriction of engine speed during no-load and light-duty operation to suppress sound. A fan with curved blades reduces air resistance and airflow noise.

Third, a time-tested muffler suppresses engine noise significantly and reduces emissions. This advanced low noise design complies with the 2000 / 14 / EC, Stage II, directive effective in the European Union from 2006.

### Hitachi Silent (HS) Fan



The HS fan is capable of reducing air resistance and air flow sound are utilized at the radiator and oil cooler for quieter operation.

### Low Noise Engine

Engine noise is effectively reduced by increasing engine mechanical strength with rigid cylinder block, and by utilizing the elaborate gear train on the flywheel side.



# SPECIFICATIONS

## ENGINE

Model .....	Cummins QSB4.5
Type .....	4-cycle water-cooled, direct injection
Aspiration .....	Turbocharger and charge air cooled
No. of cylinders .....	4
Maximum power	
SAE J1349,	
Without Fan net .....	96 kW (129 HP) at 2 000 min <sup>-1</sup> (rpm)
ISO 9249,	
Without Fan net .....	96 kW (129 HP) at 2 000 min <sup>-1</sup> (rpm)
EEC 80/1269,	
Without Fan net .....	96 kW (129 HP) at 2 000 min <sup>-1</sup> (rpm)
Bore and stroke .....	107 mm x 124 mm
Piston displacement .....	4.46 L
Batteries .....	2 x 12 V 620CCA, 80Ah, 140-min rated reserve
Air cleaner .....	Two element dry type with restriction indicator

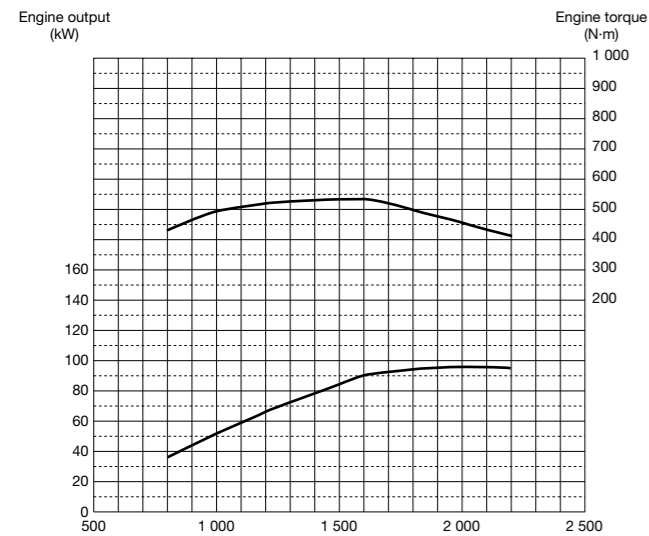

## POWER TRAIN

Transmission .....	Electrical-controlled 2 motor hydrostatic transmission with summation gear box
	Gear box: Fixed gear ratio, powershift countershaft type
Cooling method .....	Forced circulation type
Travel speed* (km/h) .....	Forward / Reverse
1st .....	7.0 / 7.0
2nd .....	13.0 / 13.0
3rd .....	20.0 / 20.0
4th .....	39.0 / 39.0

\* With 17.5-25-12PR (L3) tires

## AXLE AND FINAL DRIVE

Drive system .....	Four-wheel drive system
Front & rear axle .....	Semi-floating
Front .....	Fixed to the front frame
Rear .....	Center pivot
Reduction and differential gear .....	Two stage reduction with torque proportioning differential
Oscillation angle .....	Total 20° (+10°, -10°)
Final drives .....	Planetary final drive

## TIRES (tubeless, nylon body)

Standard .....	17.5-25 12PR (L3)
----------------	-------------------

## BRAKES

Service brakes .....	Inboard mounted fully hydraulic 4 wheel wet disc brake
	HST(Hydro Static Transmission) system provides additional hydraulic braking capacity
Parking brake .....	Spring applied, hydraulically released, wet disc type with drive through prevention mechanism

## STEERING SYSTEM

Type .....	Articulated frame steering
Steering mechanism .....	Fully hydraulic power steering with orbitrol
Steering angle .....	Each direction 40° ; total 80°
Relief pressure .....	19.6 MPa (200 kgf/cm <sup>2</sup> )
Cylinders .....	Two double-acting piston type
No. x Bore x Stroke ....	2 x 65 mm x 419 mm
Minimum turning radius at the centerline of outside tire .....	4 950 mm

## HYDRAULIC SYSTEM

Arm and bucket are controlled by Joystick lever	
Arm controls .....	Three position valve ; Raise, lower, float
Bucket controls with automatic bucket return-to-dig controls .....	Three position valve ; Roll back, hold, dump
Main pump (Load & steer) .....	Gear type 159 L/min @2 200 min <sup>-1</sup> (rpm) at 20.6 MPa (210 kgf/cm <sup>2</sup> )
Relief pressure setting .....	20.6 MPa (210 kgf/cm <sup>2</sup> )
HST charging pump .....	Gear type 41L /min @2 200 min <sup>-1</sup> (rpm) at 2.5 MPa (25 kgf/cm <sup>2</sup> )
Transmission charging pump .....	Gear type 17 L/min @2 200 min <sup>-1</sup> (rpm) at 1.96 MPa (20 kgf/cm <sup>2</sup> )
Fan pump .....	Gear type 30 L/min @2 200 min <sup>-1</sup> (rpm) at 11.8 MPa (120 kgf/cm <sup>2</sup> )
Hydraulic cylinders	
Type .....	Two arm and one bucket, double acting type
No. x Bore x Stroke ....	Arm : 2 x 125 mm x 620 mm
	Bucket : 1 x 150 mm x 445 mm
Filters .....	Full-flow 10 micron return filter in reservoir
Hydraulic cycle times	
Lift arm raise .....	6.0 s
Lower .....	3.0 s
Bucket dump .....	1.3 s
Total .....	10.3 s

## SERVICE REFILL CAPACITIES

Fuel tank .....	180.0 L
Engine coolant .....	25.0 L
Engine oil .....	14.0 L
Transmission gear box.....	10.0 L
Front axle differential & wheel hubs .....	24.0 L
Rear axle differential & wheel hubs .....	25.0 L
Hydraulic reservoir tank .....	80.0 L

# EQUIPMENT

## STANDARD EQUIPMENT

Standard equipment may vary by country, so please consult your Hitachi dealer for details.

### ENGINE

- Coolant recovery tank
- Hydraulically operated cooling fan with heat sensing system
- Fan guard
- Muffler, under hood with large exhaust stack
- Environmentally friendly engine oil drain
- Engine oil cooler
- Fuel Filter
- Quick-release fuel pre-filter with water separator function
- Air heater (For cold start)
- Air filter double element

### POWER TRAIN

- Electrically controlled HST system
- Torque proportioning differentials, front and rear

### HYDRAULIC SYSTEM

- Bucket auto leveler
- Float system
- Reservoir sight gauge
- Hydraulic filters, vertical mounting
- Joystick lever
- Two-spool main control valve
- O-Ring Seal joints

### ELECTRICAL

- 24-volt electrical system
- Standard batteries (2), 12-volt with 620CCA, 80 Ah
- Alternator, 65 A and 24-volts
- Lights: Driving with guards / Turn signals with hazard switch / stop, tail and back-up lights
- Work lights on cab, front (2)
- Work lights, rear (2)
- Horn, with push button in center of steering wheel and switch on joystick lever knob or right console

## OPTIONAL EQUIPMENT

Optional equipment may vary by country, so please consult your Hitachi dealer for details.

### ENGINE

- Air pre-cleaner
- Reverse rotating cooling fan

### POWER TRAIN

- Limited slip differential

### HYDRAULIC SYSTEM

- Three-spool main control valve
- Third spool piping
- Joy stick-lever and auxiliary lever for third function
- Multi-functional joystick lever
- Multi-functional joystick lever and auxiliary lever for third function
- Ride control system, automatic type
- Lift arm kick-out system
- Lift arm auto leveler

- Reverse warning alarm
- Monitor and alarm system, multi-function electronic audible and visual warning include
- LCD monitor display: Speedometer / Clock / Hour-meter / Odometer / Replacement intervals / Ride control /Speed range
- Gauges: Engine coolant temperature / Fuel level
- Warning lights: Engine / Transmission / Discharge warning
- Indicator lights: Turn signals / High beam / Working lights / Service / Parking brake / Stop / Brake oil low pressure / Brake oil low level / Seat belt / Glow signal / Maintenance / Forward / Reverse switch / Water separator / Over heat / Engine oil low pressure / Air filter restriction / Hydraulic oil temperature /
- 24-volt AM/FM stereo radio with clock

### OPERATOR'S STATION

- Cab
- ROPS\* / FOPS\*\* / Multi-plane isolation mounted for noise / Vibration reduction / Front and rear windshield washers / Safety glass
- Adjustable armrest
- Bi-level auto air conditioner and pressurize cab
- Front / Rear defroster
- Hot and cool box
- Sun visor
- Seat(Kab), fabric, high back, mechanical suspension, adjustable for weight-height, fore-aft position,backrest tilt, and armrest angle
- Seatback pocket
- Retractable seat belt, 50 mm
- Large tray and drink holder
- Rubber floor mat
- Adjustable steering column
- Steering wheel, textured with spinner knob
- Rear view mirrors, outside (2) and inside (2)
- Handrails and steps, ergonomically located and slip resistant
- Coat hook

### LOADER LINKAGE

- Z-bar loader linkage provides (High bucket breakout)

### BUCKETS AND ATTACHMENTS

- General purpose bucket with bolt-on cutting edges: 2.0 m<sup>3</sup> (ISO heaped)

### TIRES

- 17.5-25-12PR (L3)
- Single-piece rims

### OTHERS

- Fenders, front and rear
- Articulation locking bar
- Anti-vandal protection, includes lockable engine enclosure, and fuel fill
- Counterweight, built-in
- Drawbar, with rocking pin
- Lift and tie-down hooks
- Open type rear grill

### ELECTRICAL

- Front Working Lamps on Cab (2)
- Rear Working Lamp on Cab (2)
- 12-volt outlet

### BUCKETS AND ATTACHMENTS

- High lift arm
- Buckets (See pages 18-19)

### OPERATOR'S STATION

- Seat(Grammer), fabric, high back, air suspension, seat heating, adjustable for weight-height, fore-aft position, backrest tilt, and armrest angle, seat cushion length and angle, headrest height and angle adjustment, lumber support
- Headrest for Grammer seat
- Headrest for Kab seat
- Retractable seat belt, 76 mm

Note: \*: ROPS (Roll Over Protective Structure) Conforms to ISO 3471:1994

\*\*: FOPS (Falling Objects Protective Structure) Conforms to ISO 3449:1992 Level all

# SPECIFICATIONS

## DIMENSIONS & SPECIFICATIONS

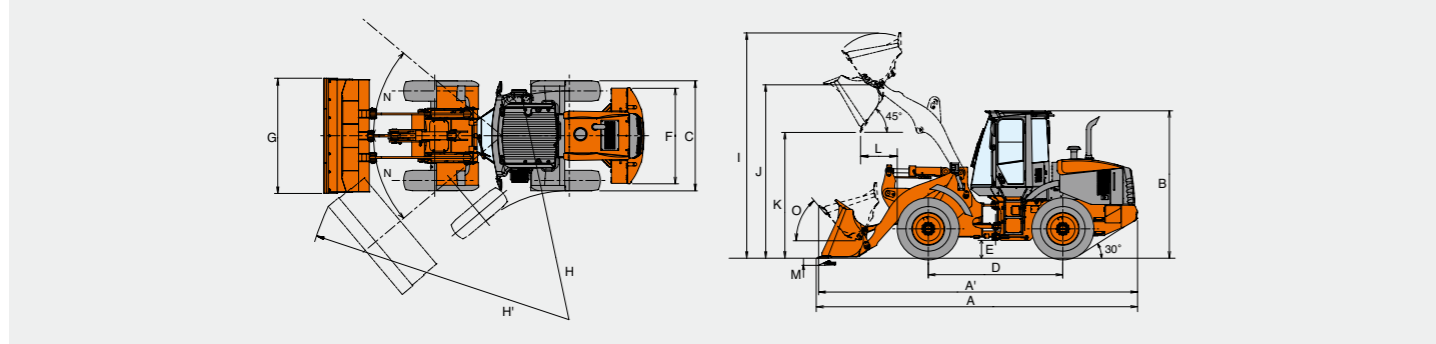

Bucket type		Standard Arm			
		General Purpose			
		With bolt-on cutting edges	With bolt-on teeth	With bolt-on cutting edges	
Bucket capacity	ISO heaped	m <sup>3</sup>	2.0	1.9	2.3
	ISO struck	m <sup>3</sup>	1.6	1.6	1.9
A Overall length		mm	6 910	7 040	7 010
A' Overall length (Traveling figure)		mm	6 870	6 960	6 930
B Overall height		mm		3 170	
C Width over tires		mm		2 390	
D Wheel base		mm		2 900	
E Ground clearance		mm		380	
F Tread		mm		1 930	
G Bucket width		mm		2 480	
H Turning radius (Centerline of outside tire)		mm		4 950	
H' Loader clearance circle, bucket in carry position		mm	5 740	5 770	5 760
I Overall operating height		mm	4 950	4 950	5 040
J Height to bucket hinge pin, fully raised		mm	3 730	3 730	3 730
K Dumping clearance 45 degree, full height		mm	2 790	2 700	2 720
L Reach, 45 degree dump, full height		mm	950	1 030	1 020
M Digging depth (Horizontal digging angle)		mm	110	120	110
N Max. roll back at carry position		deg		50	
Static tipping load *	Straight	kgf	8 050	8 170	7 990
	Full 40 degree turn	kgf	6 970	7 090	6 910
Breakout force		kN	96	104	87
		(kgf)	(9 790)	(10 600)	(8 870)
Operating weight *		kg	10 290	10 240	10 330

Note: 1. All dimensions, weight and performance data based on ISO 6746-1:1987, ISO 7137:1997 and ISO 7546:1983

2. Static tipping load and operating weight marked with\* include 17.5-25-12PR (L3) tires (No ballast) with lubricants, full fuel tank and operator. Machine stability and operating weight depend on counterweight, tire size and other attachments.

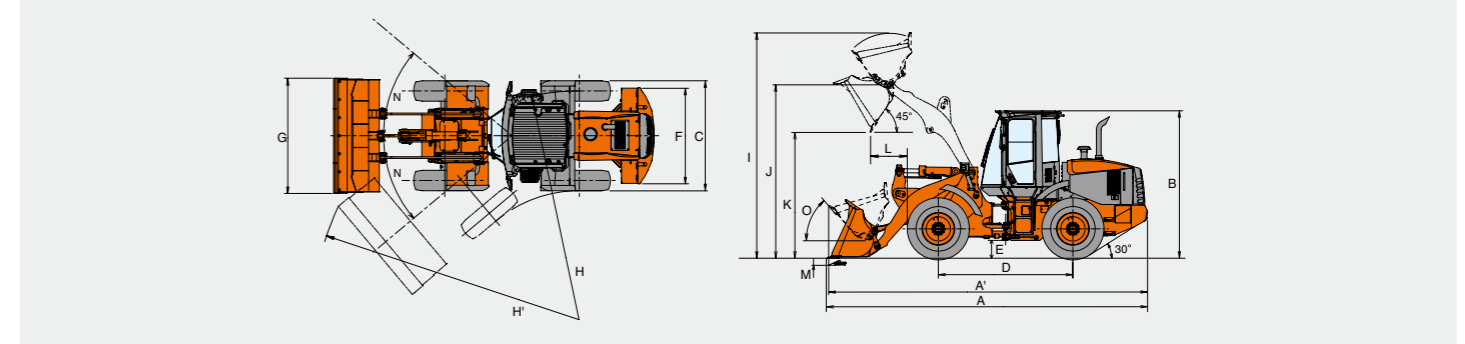

Bucket type		High Lift Arm		
		General Purpose		
		With bolt-on cutting edges	With bolt-on teeth	
Bucket capacity	ISO heaped	m <sup>3</sup>	1.6	1.5
	ISO struck	m <sup>3</sup>	1.3	1.2
A Overall length		mm	7 240	7 360
A' Overall length (Traveling figure)		mm	7 220	7 300
B Overall height		mm		3 170
C Width over tires		mm		2 390
D Wheel base		mm		2 900
E Ground clearance		mm		380
F Tread		mm		1 930
G Bucket width		mm		2 480
H Turning radius (Centerline of outside tire)		mm		4950
H' Loader clearance circle, bucket in carry position		mm	5 890	5 930
I Overall operating height		mm	5 140	
J Height to bucket hinge pin, fully raised		mm	4 090	
K Dumping clearance 45 degree, full height		mm	3 250	3 160
L Reach, 45 degree dump, full height		mm	1 020	1 090
M Digging depth (Horizontal digging angle)		mm	200	210
N Max. roll back at carry position		deg		50
Static tipping load *	Straight	kgf	6 300	6 410
	Full 40 degree turn	kgf	5 430	5 530
Breakout force		kN	114	124
		(kgf)	(11 620)	(12 640)
Operating weight *		kg	10 540	10 480

Note: 1. All dimensions, weight and performance data based on ISO 6746-1:1987, ISO 7137:1997 and ISO 7546:1983

2. Static tipping load and operating weight marked with\* include 17.5-25-12PR (L3) tires (No ballast) with lubricants, full fuel tank and operator. Machine stability and operating weight depend on counterweight, tire size and other attachments.

## BUCKET SELECTION GUIDE

### General purpose

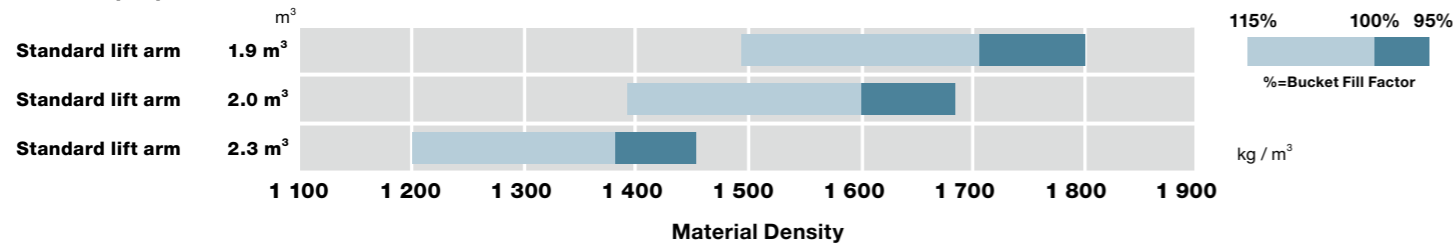

### General purpose

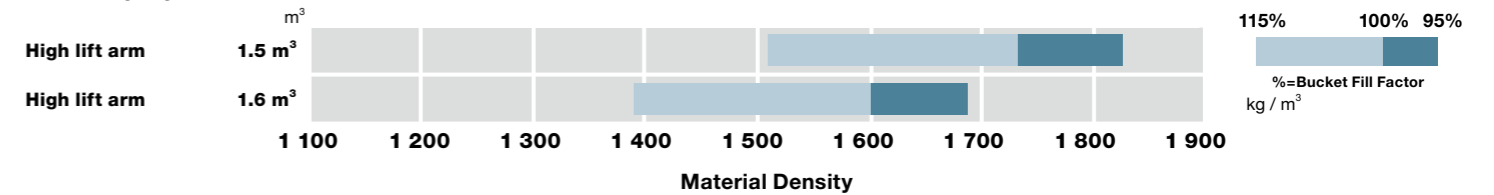

These specifications are subject to change without notice.  
Illustrations and photos show the standard models, and may or may not include optional equipment, accessories, and all standard equipment with some differences in colour and features.  
Before use, read and understand the Operator's Manual for proper operation.

